



Flood Light

HARRIER50R

50W

USER MANUAL



For safety, please read this user manual carefully before initial use.

eXterrain reserves the right to revise the manual at any time. Information and specifications within this manual are subject to change without notice. eXterrain assumes no liability or responsibility for any errors or omissions. Please consult eXterrain for any clarification or information regarding this item.

www.exterrain.com.au

Safety Instructions

WARNING

- Do not open this device, there is no user-serviceable parts inside and will affect waterproof seal. Risk of electric shock.
- Do not look at the light source when the device is on.
- Nothing should be in front of the light less than .5 meters away from device when in use
- **CAUTION:** This unit's housing may be hot during and after operation.
- Install this device in a location with adequate ventilation, at least 6 inch (15 cm) from adjacent surfaces.
- Do not leave any flammable material within 50 cm of this unit while operating or connected to power.
- ALWAYS ensure care is taken when installing electrical wiring and do not place undue force on cabling or wiring as this may result in electrical damage/failure.
- Do not operate this device if the housing, lenses, or cables appear damaged.
- Do not connect this device to a dimmer or rheostat.
- In case of a serious operating problem, stop using immediately.
- The maximum ambient temperature is -40 ~ 85°. Do not operate this device at higher temperatures.

General product information

Features

- Flood Beam (90°+ 60°)
- Reverse polarity protection
- UV resistance
- Shock resistance
- Rust/corrosion/freeze resistance

Specifications

- Voltage: DC10-30V
- Power: 50W (5W x 10) LEDs
- Operating Temperature: -40° ~ 85°
- Current: 1.9 / 3.8A
- Colour Temperature: 6500K
- Luminous Flux: 4250LM
- IP68 Waterproof
- Lens: Lexan PC Shatterproof Front Cover
- Chassis: Die-cast Aluminium Alloy
- Finish: Anodised Polyester Powder Coating

Product Installation

Connector and wiring

This device comes with a built in male DT connector. If DT connector is not required, an alternative option to support the connection is to cut the wire and hard wire it. See below diagram.

Please note: Drawing is example only – wiring loom is not included.

FLOOD LIGHT

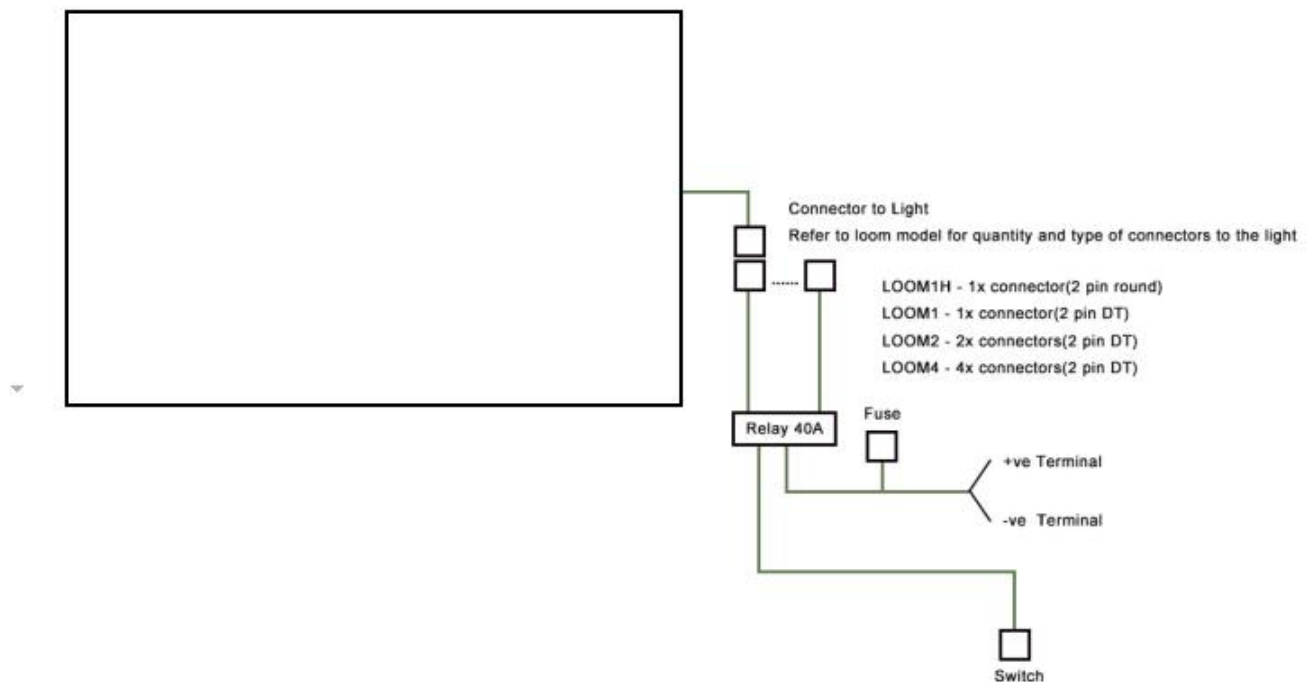

This device can be mounted in many orientations provided each individual device is secured by the use of the correct mounting bracket.

Please refer to optional mounts section regarding specific mounting options.

IMPORTANT NOTE:

- eXterrain does not take responsibility for ensuring the installation of these products comply with your local regulations.
- We recommend using a licensed auto electrician when installing this device.
- Please ensure you follow the installation instructions carefully if you choose to install this device independently.

Dimensions

109 x 118 (H) x 75 (W) (mm)

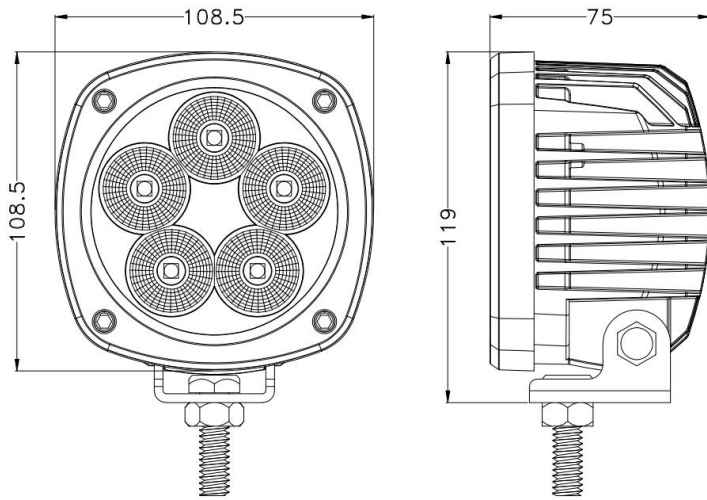

Beam Coverage

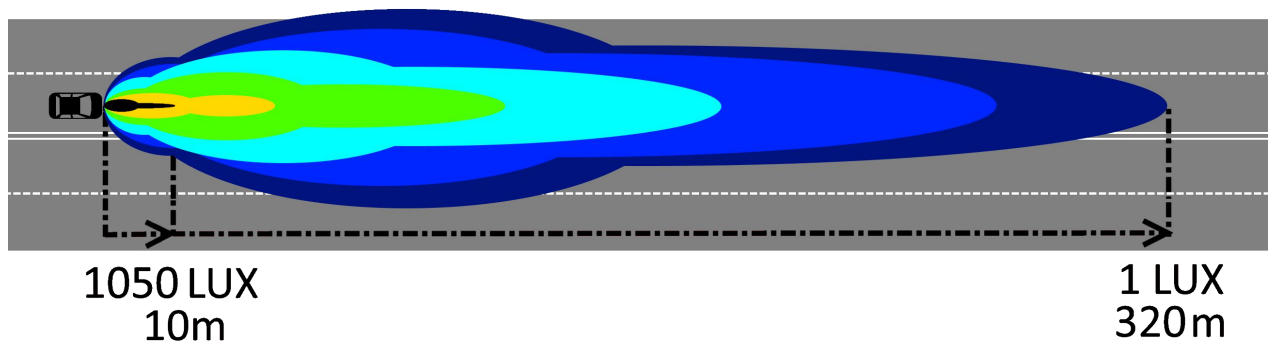

Installation Option included:

Installation method for all eXterrain light series include mounting brackets. The diameter of the hole for these brackets is 10mm.

Optional Loom

For more information on eXterrain's various optional loom visit: www.exterrain.com.au.



Warranty

This product has a lifetime guarantee warranty. Please contact your authorised eXterrain reseller for any warranty queries.



www.exterrain.com.au